

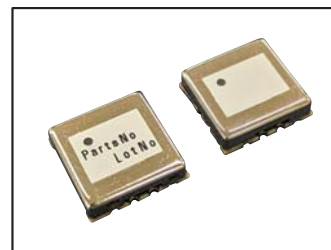

VC022 Series (Dual Band) Low-Profile Voltage Controlled Oscillators

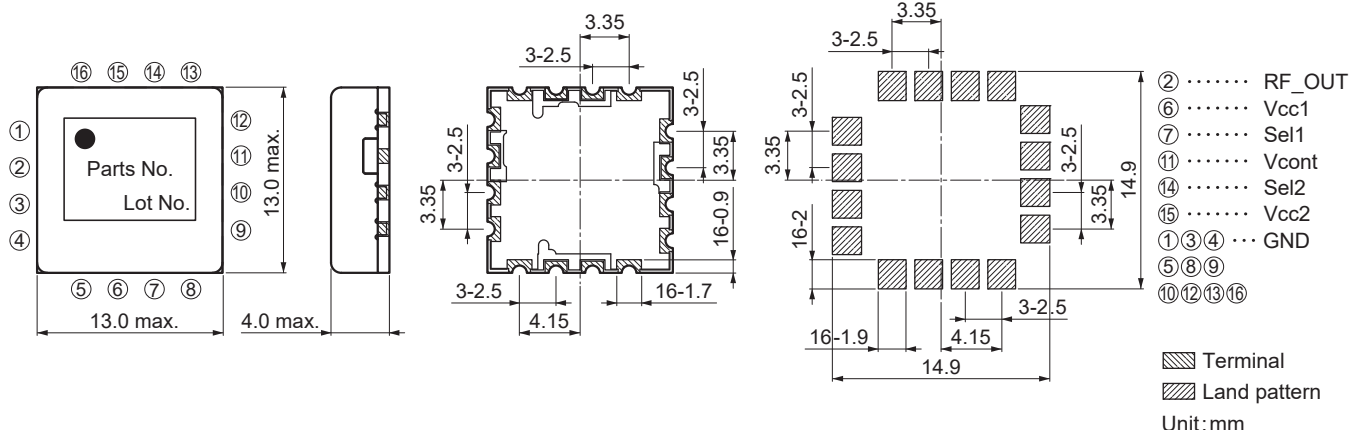

Configurations, Recommendable footprint, Dimensions



Reference Performance Specification

Item	Conditions / Ratings	Maximum Rating	Unit
Power Supply Voltage 1 (Vcc1)	4.8	5.5	V
Power Supply Voltage 2 (Vcc2)	4.8	5.5	V
Control Voltage (Vcont)	16.0	17.0	V
Switching Voltage 1 (Sel 1)	3.3	-	V
Switching Voltage 2 (Sel 2)	3.3	-	V

Item	Conditions / Ratings	Maximum Rating	Unit
Load Impedance	50 (Nominal)	-	Ω
Operating Temperature Range	- 30 to + 85	-	°C
Storage Temperature Range	- 40 to + 85	-	°C

Reference Electrical Specifications

Item	Conditions		Specification Value		Unit
			+ 25±3°C	- 30 to + 85°C	
Oscillation Frequency (F)	Lo Band (Sel 1)	Vcont = 0.5V	-	1500(max.)	MHz
		Vcont = 16.0V	-	1800(min.)	
	Hi Band (Sel 2)	Vcont = 0.5V	-	1800(max.)	
		Vcont = 16.0V	-	2080(min.)	
Frequency Control Sensitivity	(F[16V] - F[0.5V]) / 15.5V		23(typ.)	-	MHz / V
Output Level	-		-	0±6	dBm
C / N	Lo Band (Sel 1)	Offset = 10kHz	- 109(typ.)	- 101(max.)	dBc / Hz
		Offset = 100kHz	- 129(typ.)	- 121(max.)	
	Hi Band (Sel 2)	Offset = 10kHz	- 108(typ.)	- 100(max.)	
		Offset = 100kHz	- 129(typ.)	- 121(max.)	
Current Consumption	-		-	20(max.)	mA
Harmonics	Second Harmonic		- 10(max.)	-	dBc
	Third Harmonic		- 20(max.)	-	
Frequency Power Supply Voltage Fluctuation	Vcc=4.8±0.2V 4.8V reference		±500	-	kHz
Frequency Load Variation	VSWR≤2 All Phase 50Ω reference		±1500	-	kHz

*Note

- 1) Unless otherwise specified
Power supply voltage = 4.8V, oscillation frequency 1500 to 2080MHz, load = 50Ω, specified measurement circuit.
- 2) Recommended pads
Due to the possibility of shorts in areas other than the land pattern, be sure to take insulation measures.

Specifications of products are subject to change without notice.

e-02006-vco22-low-profile-p01-02



株式会社 **MKT TAISEI** Co., Ltd.

<< Head Office >> 3-10-8, Nohagi 1st Bldg, Minami-Ikebukuro, Toshima-ku, Tokyo, 171-0022, Japan.
 PHONE : 81-3-3982-0029 FAX : 81-3-3986-1537 E-mail : info@mkt-taisei.com
 << Kansai Branch >> 3-18-9, Nishi-Nakajima, Yodogawa-ku, Osaka-City, 532-0011, Japan.
 PHONE : 81-6-6390-7264 FAX : 81-6-6390-6945

http://www.mkt-taisei.co.jp/